

Analytic Approach for the Effect of Interfacial Tension on the Liquid Drop Flow in a Simple Packed Bed

In-Hyeon JEONG and Sung-Mo JUNG*

Graduate Institute of Ferrous Technology (GIFT), Pohang University of Science and Technology (POSTECH), Cheongam-ro 77, Nam-gu, Pohang, 790-784 Korea.

(Received on August 24, 2015; accepted on December 25, 2015)

In a packed bed system, the interfacial tensions of liquid drops highly affect their flow behavior by changing the direction of the interfacial tensions in the liquid-solid-gas interface. The vertical directional interfacial forces of a liquid drop in a packed bed of small particles were calculated using a 3-D analytic calculation model. Regardless of the wettability of a solid surface, the interfacial tension induces the resisting force against the gravitational force. In short, the interfacial tension limits the flow of a liquid drop along the direction of the gravitational force. In case two liquid drops of different phases directly contact each other in a packed bed, one of the interfaces of each drop is shared, and the influence of the interfacial force decreased so that the liquid drops could move down through the void between particles compared with the case a single drop. If the shared interface of two liquid drops of which one is non-wettable and the other is wettable has lower contact angle than that of the liquid-gas interface of the liquid drop, then the drops experience the downward force along the direction of the gravity in the larger range of the position in the packed bed.

KEY WORDS: blast furnace; packed bed; liquid hold-up; interfacial force; wettability; contact angle.

1. Introduction

In the lower part of the blast furnace (BF), which is a trickle coke bed system, there coexist various phases such as gaseous phases (CO, CO₂ and N₂), liquid phases (molten iron and slag) and solid phases (coke and coal powder).¹⁾ Since many different phases exist and interact each other physically and chemically, it is of importance to understand their flow behavior and mutual interaction for the efficient and stable operation of the BF. Even though several researchers have tried to clarify the phenomena in the lower part of the BF, the inside view of the complex system has not been clearly observed yet. For this reason, not only experimental approaches but also various analytical and computational tools have been developed to see the internal phenomena clearly.²⁾

In view of the counter-current characteristics of ironmaking reactors such as BF and smelter, the smooth physical interactions among different phases are of great importance. From this viewpoint, the appropriate control of liquid hold-up in the lower part has been one of the key issues for the stable operation of the BF.^{3–6)} Hot metal and slag in the BF flow as droplets rather than as continuous channels, which is ascribed to high surface tensions of liquid metal and slag at 1 500°C.^{7,8)} Typically, it is well known that the surface tensions of liquid metal and slag are 1.1 and 0.4 N/m, respectively.³⁾ The high values might cause the complex behavior

of liquid flow in the lower part of the BF and bring about the liquid hold-up as well.

Inappropriate hold-up of liquids in the lower part of the BF will deteriorate the gas permeability and its extent increases with decreasing the particle size of packed bed.^{3,4)} That is, the small solid particles increase the physical interaction between the liquid drops and surfaces of the particles. Typically, the increased hold-up of liquids such as hot metal and molten slag decreases the counter-current gas permeability and sometimes it makes BF operation unstable.⁹⁾ In particular, in case solid particles such as coke and char in the reactors become smaller, the flows of liquid metal and slag are highly deteriorated by the physical interactions between the solid and liquid. The surface tension will determine a specific contact angle of liquid metal or slag on a solid substrate, which ultimately establishes a force balance in a packed bed system.¹⁰⁾

The interaction between solid substrates such as packed beds and liquid materials have been studied by several researchers.^{12–15)} Among them, Jeong *et al.* recently found out that the permeability of liquid iron in a coke bed could be enhanced by adding a new liquid material of different phase, namely, slag. In their experiments, they intentionally added both the molten iron and liquid slag into a coke bed at 1 500°C, and observed that their flows became enhanced compared with the single flow of iron and slag in the coke bed.¹⁵⁾ They also used a two dimensional computational model to show that the interfacial tension of a liquid drop drastically affect the force balance of the drop in a packed bed system.

* Corresponding author: E-mail: smjung@postech.ac.kr
DOI: <http://dx.doi.org/10.2355/isijinternational.ISIJINT-2015-495>

The current investigation aims to clarify the flow behavior of multiphase liquids in packed bed systems. Based on the previous study by Jeong *et al.*,¹⁵⁾ it was attempted to figure out how two liquid materials of different phases interact in a packed bed of small-sized particles. For more realistic approach, a 3-D analytical model was applied to simulate the multi-phase liquid flow behaviors in a packed bed. Based on the results obtained in the current study, the insight into the multiphase interactions of liquid materials in the lower part of the BF might be clearer than before. Furthermore, it could help develop a new operational scheme for controlling the liquid hold-ups of liquid iron and slag in the complex packed bed system.

2. Analytic Modeling for a Liquid Drop Flow through a Simple Packed Bed of Three Spherical Particles

2.1. Schematic View of a Liquid Drop Flow through a Packed Bed

In order for a liquid drop to pass through a narrow slit between solid particles, the drop should deform following the shape of the slit. If the slit is smaller than the drop, the drop cannot pass through the slit without deforming its own shape. **Figure 1** illustrates how non-wetting and wetting liquid drops pass through a narrow slit between solid particles, respectively. The non-wetting liquid drop slightly deforms its shape while the wetting liquid drop significantly deforms its shape and fits in with the slit so that it could pass through the particles.

A liquid material macroscopically changes its shape with ease just as water in a cup forms the shape of the cup. However, in a microscopic view, the interfacial tension of a liquid material does not always allow it to deform following the shape of contacting solid materials. Interfacial tension is a force acting on liquid interface in close contact with the other phases. The tension induces the decrease in the area of the interface. Because of the interfacial tension, a liquid material whose interface in contact with other materials

of different phases has its own specific shape around the interface. Saito *et al.* well described the shape of a liquid interface in a three-dimensional packed bed in terms of the contact angle between liquid and solid phases.⁵⁾ Their assumption of the interface shape between two different phases corresponds to the idea in which the interface shape is completely determined by the interfacial tension just as Young-Laplace formula has described.

In the lower part of a blast furnace, molten iron and liquid slag coexist and they share a interface since they have different interfacial energies. In this study, a simple flow experiment of molten iron and slag in a coke bed was performed. The detail of the experimental method was introduced in the paper of Jeong *et al.*¹⁵⁾ On the experiment, the positions of molten iron and slag in a coke bed were observed and photographed by a digital camera equipped with a magnifying glass in **Fig. 2**. The molten iron and liquid slag shared a clear and smooth interface between them without remaining gas voids. Even though the contact angle of the interface could not be defined from the result, the smooth interface suggests that the interfacial force between the two phases may dominantly control the shape without any specific divergence factor which disarranges the interface. From this observation, the interface shape of a liquid drop was adopted to be dominantly controlled by the interfacial tension in this study.

2.2. Deformation of a Liquid Drop with High Interfacial Tension in a Packed Bed

In a packed bed system, one of the forces which induces the downward movement of a liquid drop is the gravitational force. However, there is another significant force which determines the movement of the liquid drop. It is the interfacial force. **Figure 3** illustrates how a liquid drop of high interfacial tension behaves in a simple packed bed system. If the liquid drop has high and low interfacial tensions against solid and gas phases, respectively, then it rarely changes its spherical shape in order not to increase the area of the

(a) A liquid drop passing through a narrow slit between solid particles

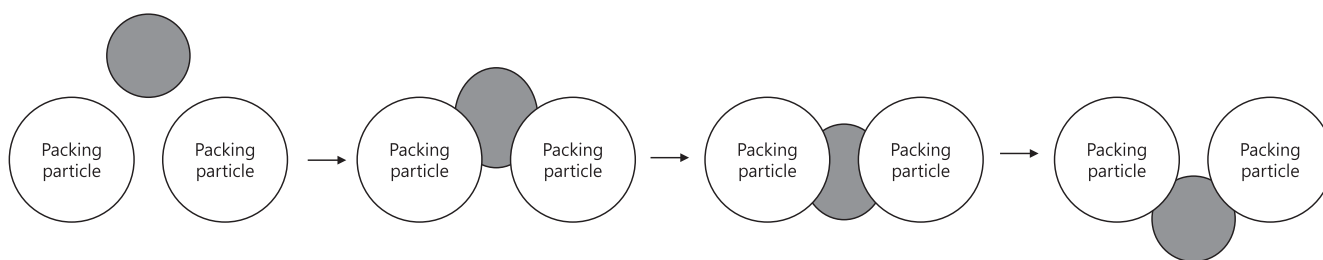

(b) A liquid drop passing through a narrow slit between solid particles

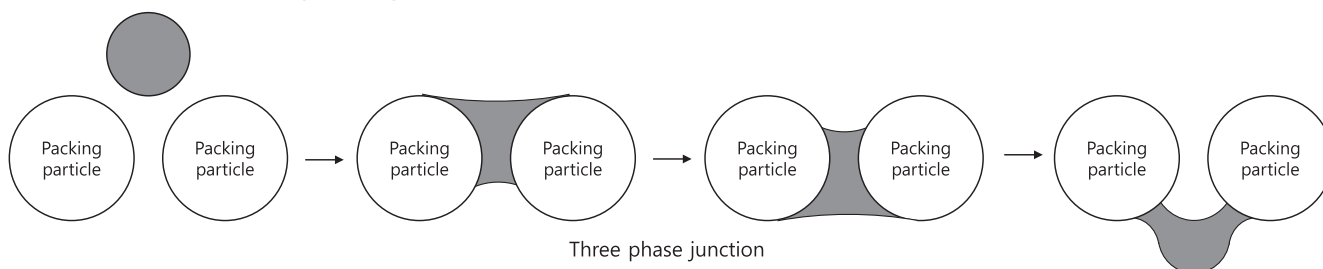

Fig. 1. Illustration of (a) a non-wetting and (b) a wetting liquid droplets passing through a slit between particles.

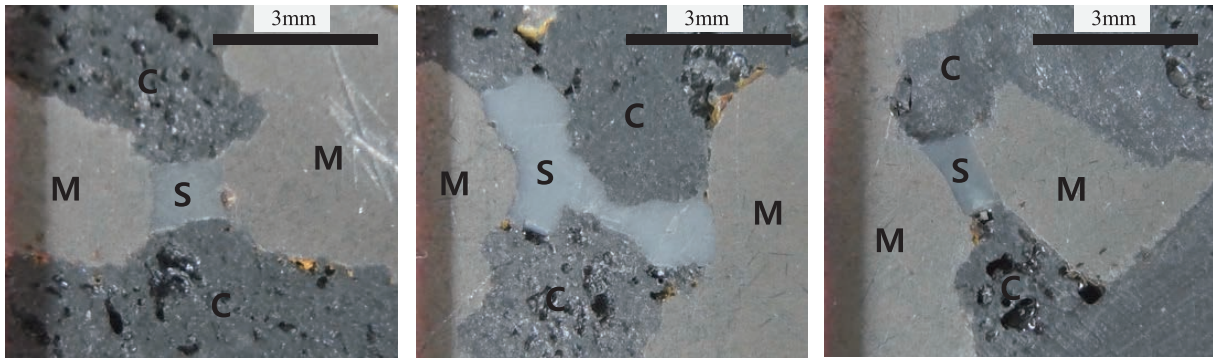
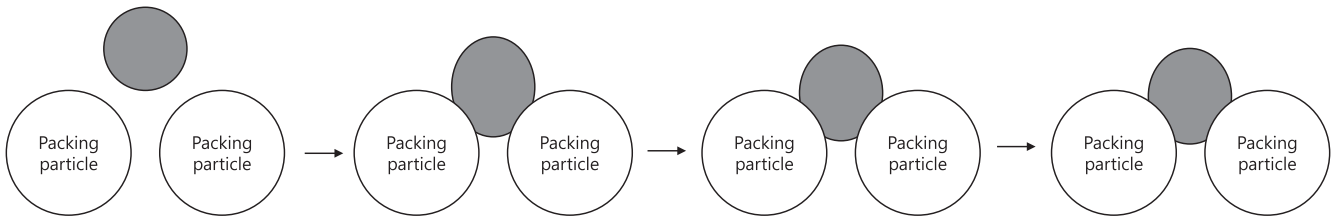

Fig. 2. Optical observation of molten iron (M) and liquid slag (S) in coke bed (C).

(a) A liquid drop holding in a narrow slit between solid particles



(b) A liquid drop holding through a narrow slit between solid particles

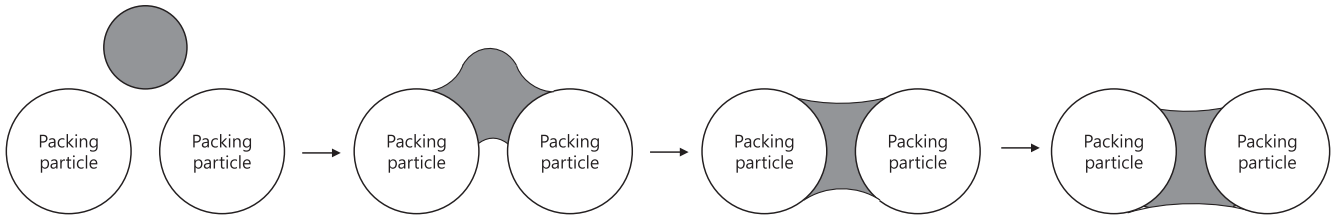

Fig. 3. Illustration of (a) non-wetting and (b) wetting behaviors of liquid drops in a narrow slit between particles.

liquid-solid interface of the high interfacial tension as in Fig. 3(a). Then the drop cannot pass through the narrow slit between the solid particles. On the other hand, if the liquid drop has high and low interfacial tensions against gas and solid phases, respectively, then it easily changes its shape in order to increase the area of the liquid-solid interface which has a lower interfacial tension.

Young-Laplace formula nicely describes the force balance induced by the interfacial tension as shown in Fig. 4. For a liquid drop on a solid substrate, the shape of the liquid drop at the gas-liquid-solid interface is determined by the interfacial tensions of the gas-liquid, liquid-solid and solid-gas interfaces. For example, if the gas-liquid interfacial tension of a liquid drop is much higher than that of the other tensions, then the drop tends to decrease the gas-liquid interfacial area. Thus, the interfacial force illustrated by the thick arrow in Fig. 4(a) is applied to the gas-liquid-solid interface. On the other hand, if the gas-liquid interfacial tension is much lower than the others, then the drop tends to increase the gas-liquid interfacial area. So, the interfacial force illustrated by the thick arrow in Fig. 4(b) is applied to the gas-liquid-solid interface.

2.3. Magnitude of Interfacial Force over the Gravitational Force

A length, in which the interfacial force of a liquid material becomes significant, is called a capillary length.¹⁶⁾ It is defined as $(\gamma/\rho g)^{1/2}$, where γ and ρ are the interfacial tension [N/m] and density [kg/m³] of the liquid drop, respectively, and g is the gravitational acceleration [m/s²]. When a liquid drop passes through a narrow void which has a diameter less than the capillary length, the movement of the drop is highly influenced by the capillary force. Molten iron and liquid slag produced in ironmaking process have their interfacial tensions of 1.1 and 0.4 N/m, respectively.^{2,3)} Compared with that of water (0.067 N/m), the values are much larger. Therefore, it is natural to consider that molten iron and liquid slag might be under the significant influence of their interfacial forces in the coke bed of a BF. The capillary lengths of the iron and slag can easily be calculated to be about 4 mm.

3. Calculation Methods

3.1. 3D Analytic Modeling of a Liquid Drop Flow in a Simple Packed Bed System

To calculate the flow of a liquid drop in a simple packed bed system, a simple 3-dimensional model consisting of

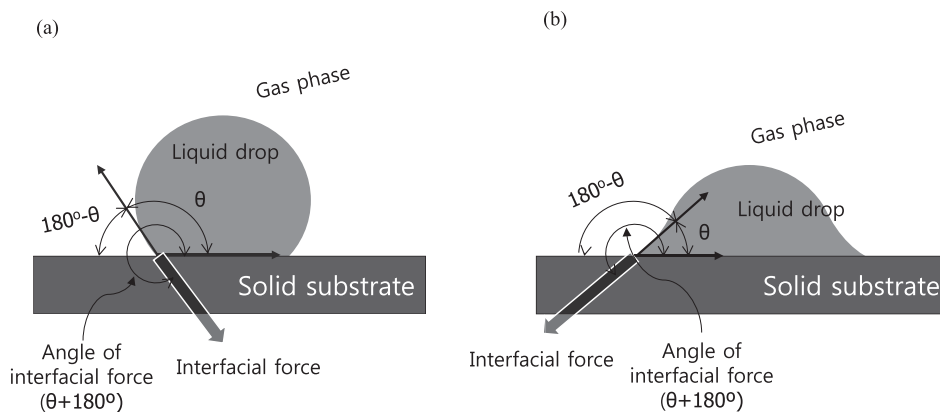

Fig. 4. Illustration of interfacial forces acting on the surfaces of (a) a non-wetting drops and (b) a wetting drop.

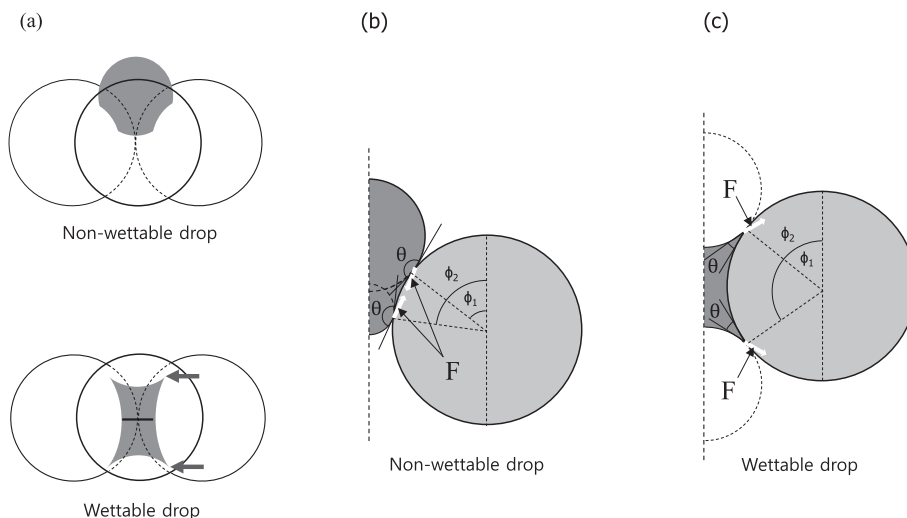

Fig. 5. Illustration of (a) shapes of liquid drops in closed packed three particles with different wettabilities and the detailed shapes of the drops in terms of their contact angles with (b) non-wetting and (c) wetting characteristics.

one liquid drop and three solid particles was adopted as shown in Fig. 5. When a liquid drop contacts the top of three packed particles, two cases of contacting situation can be predicted. If the drop has non-wetting characteristic, it would not deform much and would stay on the particles as the upper illustration in Fig. 5(a). However, in the case of a wettable drop, it would form a liquid bridge between the particles as the lower illustration in Fig. 5(a). Under the assumption that the sizes of the particles are small enough to guarantee that the capillary effect is dominant, the non-wettable drop is considered to be a union of two perfect spheres which have appropriate radius so that the contact angle (θ) is fixed in Fig. 5(b). In the same manner, the wettable drop is considered to fill the rest of a union of two virtual perfect spheres in Fig. 5(c). And, the shapes of the drops in the void between the three particles are defined to follow the concave shape of the void for the 3-dimensional form. Figure 6 illustrate the shape change of a liquid drop while it is passing through a packed bed of three particles. The three dimensional shape change was considered for the calculation in this study.

Since the current study only deals with the flow of liquid drop in packed beds of small-sized particles, it is reasonable to assume that the shapes of drops are determined by the

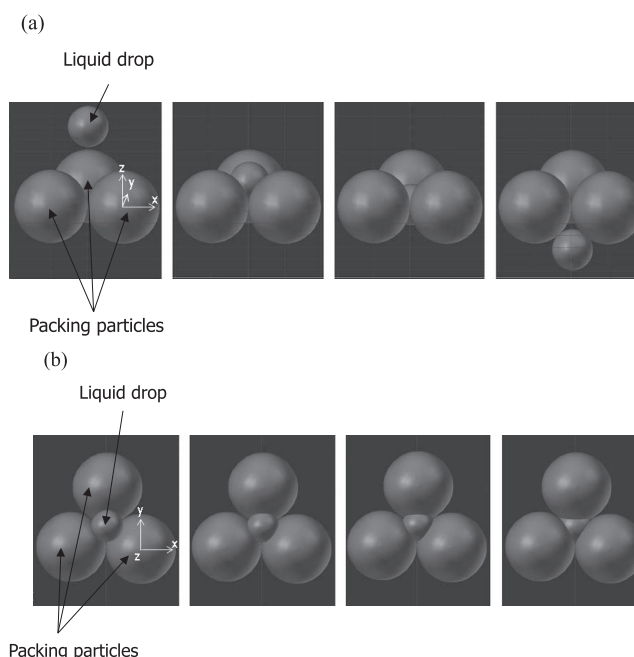

Fig. 6. Illustration of the three dimensional shape change of a liquid drop passing through a packed bed of three particles; (a) Front view and (b) Top view.

compositions of perfect spheres. Once the packing particle size, the drop volume and the contact angle are given, then the radius and positions of the virtual spheres are uniquely determined depending on the position of the liquid drop. Naturally, the shape of the drop is also uniquely determined.

Once the shape of the drop is fixed, then the direction of the gas-liquid interfacial tension can be obtained by the white arrows which are indicated by the character ‘F’ in Figs. 5(b) and 5(c). In order to derive the directions and magnitudes of the interfacial tensions, the positions of the interfaces of the gas-liquid-solid phase should be defined. In this study, the positions were traced by the angles defined from the z direction of a particle which are indicated as ϕ_1 and ϕ_2 in Figs. 5(b) and 5(c). Then, the unit direction vector of the interfacial tension which is expressed as horizontal and vertical components can be defined as $(\cos(\phi_1 - \theta), \sin(\phi_1 - \theta))$ for the interface traced by ϕ_1 and $(\cos(\phi_1 + \pi + \theta), \sin(\phi_1 + \pi + \theta))$ for the interface traced by ϕ_2 in Figs. 5(b) and 5(c).

The typical unit of interfacial tension is the force over length (N/m). In order to translate the interfacial tensions into the corresponding interfacial forces, the lengths of the gas-liquid-solid interfaces should be obtained. **Figure 7** illustrates how the lengths of the interfaces are defined. Since a liquid drop fills the void between three particles, 1/6 of the surface of each particle is in contact with the drop. Then the length of each interface for one particle can be defined as $2\pi R \sin(\phi_1) \times \frac{1}{6}$ and $2\pi R \sin(\phi_2) \times \frac{1}{6}$ for the interfaces corresponding to ϕ_1 and ϕ_2 , respectively, where R is the radius of a packing particle in Figs. 7(b) and 7(c).

From the above mathematical notations, the interfacial forces for one particle are obtained by $\frac{1}{3} \gamma \pi R \sin(\phi_1) (\cos(\phi_1 - \theta), \sin(\phi_1 - \theta))$ and $\frac{1}{3} \gamma \pi R \sin(\phi_2) (\cos(\phi_2 + \pi + \theta), \sin(\phi_2 + \pi + \theta))$ by multiplying the interfacial tensions and the lengths for both interfaces where γ is the gas-liquid interfacial tension. If only the vertical components of the interfacial forces are extracted, the vertical directional interfacial forces are $\frac{1}{3} \gamma \pi R \sin(\phi_1) (\sin(\phi_1 - \theta))$ and $\frac{1}{3} \gamma \pi R \sin(\phi_2) (\sin(\phi_2 + \pi + \theta))$. In this study, only the vertical interfacial forces are important because they determine whether the liquid drop would move up or down according to the gravitation force exerting

on the mass of the drop.

3.2. Magnitude of the Forces Acting on a Liquid Drop in a Packed Bed

In a packed bed system of small-sized particles, the interfacial tension forces and the gravitational force dominantly affect the moving behavior of a liquid drop. Focusing on the vertical movement of a liquid drop, the summation of the vertical interfacial tension forces and the gravitational force on the liquid drop would make the drop move up/down through the void or halt in the void. As previously mentioned, once the volume and interfacial tension of a liquid drop and the radius of a packing particle are given, then the other terms relating the interfacial tension forces are automatically determined. In addition, if the density of the liquid drop is given, the magnitude of the gravitational force is also determined. In the current study, the volumes, interfacial tensions and contact angles of a liquid drop and the particle size were set as shown in **Table 1**. The volume of the drop was set to be smaller than the particle size and larger than the void size. The interfacial tensions and contact angles of the liquid drop and the particle size were set based on Jeong *et al.*'s study.¹⁵⁾

3.3. Calculation Procedure

A liquid drop in the packed bed of three particles has its unique shape depending on its position in the void between the particles as already mentioned. Thus, for each ϕ_1 value illustrated in Fig. 7, the corresponding ϕ_2 is automatically calculated by numerically increasing the value of ϕ_2 from the value of ϕ_1 until the volume defined between the angles becomes the initial volume of the liquid drop. Then vertical interfacial forces for ϕ_1 and ϕ_2 can be calculated. With this concept, the overall calculation procedure is as follows:

- 1) The parameter introduced in Table 1 is given.
- 2) The gravitational force acting on the liquid drop is calculated.

Table 1. Volume of liquid drop, particle size of the packed bed.

	Liquid drop Volume (Ncc)	Particle radius (mm)	Interfacial tension with gas phase (N/m)
Non-wettable drop	0.5, 1, 5	3	1.1
Wettable- drop	0.5, 1, 5	3	0.4

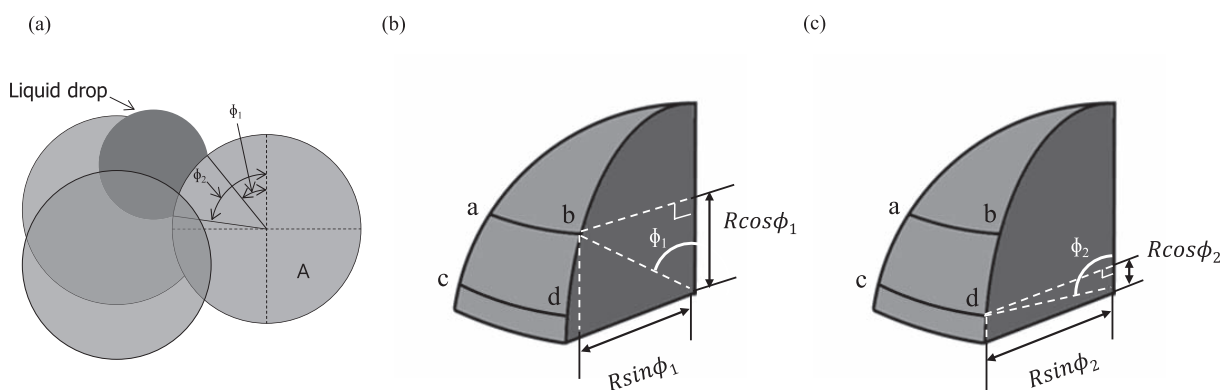

Fig. 7. Illustration of (a) the position of a liquid drop in a packed bed of three particles and the detailed positions and lengths of the (b) upper and (c) lower three phase junctions.

- 3) A proper ϕ_1 is given so that one position of the interface can be obtained.
- 4) ϕ_2 is numerically calculated so that the volume of the liquid drop is well defined between ϕ_1 and ϕ_2 .
- 5) At given ϕ_1 and ϕ_2 above, the vertical interfacial forces are calculated.
- 6) The force balance between the gravitational force and the vertical interfacial forces are calculated.
- 7) A new ϕ_1 value is given which is slightly larger than the previous ϕ_1 .
- 8) The procedure from 4) to 7) is repeated while ϕ_1 is less than 180 degrees.

By the above procedure, the force balance between the interfacial forces and the gravitational force acting on a liquid drop in a packed bed of three particles were determined. In addition, the direction and magnitude of the sum of the forces were plotted against the given ϕ_1 which indicates the upper interface position of the liquid drop. The plots will be shown in the following section.

3.4. Force Balance of Two Liquid Drops in a Packed Bed

In the lower part of a blast furnace, molten iron and liquid slag have their interfaces of high interfacial energy and they do not merge even though they contact each other. To simulate the multiphase flow of liquid drops in a packed bed, the situation was illustrated in Fig. 8(a), and the force balance between the gravitational force on the two drops and the interfacial forces were calculated taking three interfacial forces into account. They are the interfaces of liquid drop-1 to gas, liquid drop-1 to liquid drop-2 and liquid drop-2 to gas. To specify the situation, the liquid drop-2 of wetting property was assumed to half in the void between the particles, and liquid drop-1 of non-wetting property was assumed to approach the void filled with the liquid drop-2 in Fig. 8(a). The way to define ϕ_3 tracing the lower interface position of the liquid drop 2 was same as that to define ϕ_2 . Since the wettability of the two liquid drops affects the interfacial forces of the interface, two situations, in which the non-wettable liquid drop-1 remained non-wettable in the

interface between liquid drop-1 and liquid drop-2 shown in Fig. 8(b) and the non-wettable liquid drop-1 became wettable in the interface as in Fig. 8(c), were assumed and the force balances were calculated. The calculation procedure is the same as that introduced in the previous section.

4. Results and Discussion

4.1. Force Balance of Liquid Drops in a Simple Packed Bed

The force balance for a non-wettable, wettable liquid drops and both of them in a packed bed of three particles were calculated. The radius of a particle in the packed bed and the volume of a liquid drop were set to be 3 mm and 1 cc, respectively. The properties of the liquid drops are given in Table 2.

As shown in Fig. 9, the non-wettable (NW, ■) and wettable (W, ◆) drops are under the downward forces (negative force) when the interface positions (ϕ_1) are less than 80° , which make the drops move down. However, if the ϕ_1 becomes larger than 80° , the upward forces (positive force) became dominant so that the drops should stop moving down at around 80° . On the other hand, when NW and W drops meet together (NW-W, ◆) in the packed bed, they are subject to the upward force only after the ϕ_1 becomes more than 105° . Moreover, if the contact angle at the interface between the NW and W drops is 45° (NW-W, ○), which is much less than that between the NW drop and gas phase, then the drops are under the upward force only after the ϕ_1 reaches more than 140° . This calculation result suggests that the shared interface between two liquid drops of different phases might decrease the interfacial force counterbalancing the gravitational force. It also showed that the change in the contact angle of NW drop to wettable and that of W drop to non-wettable might make their flow be fluent in the packed bed of small particles.

4.2. Effect of Volumes of Liquid Drops on Force Balance in a Packed Bed

In a packed bed, liquid drops passing through the void

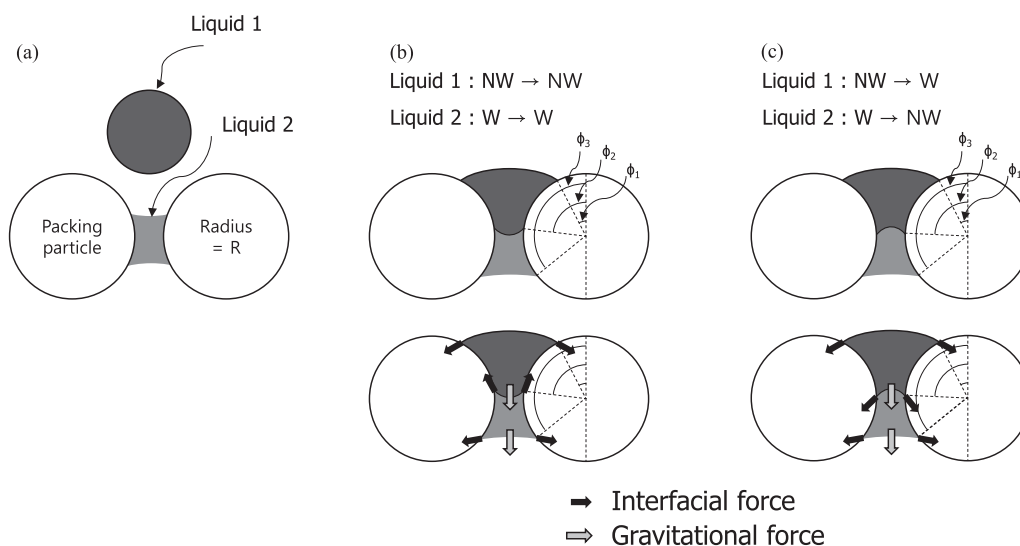
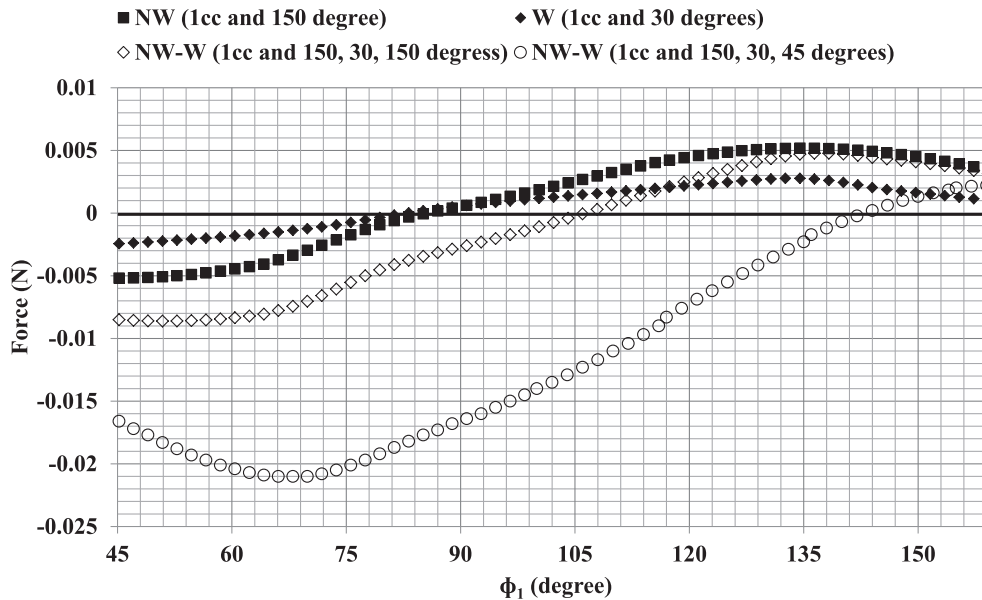

Fig. 8. Illustration of the directions of forces acting on the two liquid drops of different phases based on their wettabilities.

Table 2. Drop density, interfacial tensions and contact angles using different liquid drops.

	Density (kg/m ³)	Interfacial tension with gas phase (N/m)	Interfacial tension with each other (N/m)	Contact angle with gas phase (degree)	Contact angle with each other (degree)
Non-wettable drop	6 700	1.1	1.0	150	Various
Wettable-drop	2 600	0.4	1.0	30	Various

Fig. 9. Force balance plot of 1 cc metal and 1 cc slag drops in the packed bed.

could have various shapes and volumes depending on their physical properties and the void size of the packed bed. In order to reflect the effect of the liquid volume, it was attempted to calculate the force balance in the liquid drops varying their volumes.

Figures 10 and 11 show the calculation results of the force balances in case the volumes of liquid drops are 0.5 and 5 cc, respectively. Regardless of the volumes, the single liquid drops of NW (■) and W (◆) conditions are under upward force before the drops' upper interfaces (ϕ_1) reaches 90°. However, when the both drops coexist in the packed bed, the drops (◻ and ◊) take the downward force until their ϕ_1 become 105° even though the contact angle between the NW and W drops is more than 150°. As same as the result shown in Fig. 9, if the contact angles between NW and W drops decrease, the drops (△ and ○) are under the downward force in the wide range of the interface positions (ϕ_1).

4.3. Mechanism of the Change in Force Balance Induced by the Variation of Contact Angle

As previously explained, a liquid drop passing through a narrow void is in the field of interfacial force as well as the gravitational force. In addition, the interfacial force typically acts to hold the liquid drop in a specific position in the void, namely, resulting in liquid hold-up. In case liquid drops of NW and W properties are held between the particles in a packed bed, the vertical components of the interfacial and gravitational forces acting on the weight of the drops are summed to be zero as shown in **Fig. 12(a)**. In **Fig. 12(a)**, the black arrows represent the interfacial forces and the grey

arrows represent the gravitational forces. In case two liquid drops of different phase contact each other, they share one interface of each drop so that the effect of the interfacial force decreased as shown in **Fig. 12(b)**. In other words, the drops obtain one interface between NW and W drops instead of losing two interfaces between NW drop and gas phase and between W drop and phase gas phase. Therefore, the liquid drops experience less upward force compared with the single drops even though their contact angles do not change.

On the other hand, if the NW and W drops change their contact angles in the shared interface, then the interfacial forces assist to act in the same direction as the gravitational force. Then the shared interface which had limited the liquid flow turned out to help improve the flow as shown in **Fig. 12(c)**.

In the whole results shown in **Figs. 9–11**, no sudden change of force acting on the liquid drop, which may result from the breakage or dispersion of the drop at a high ϕ_1 value, was observed because the phenomena were not considered in the force calculation. Instead of that, a smooth liquid bridge at the high ϕ_1 was assumed to be formed without breakage as in **Fig. 12(d)**. The force balance calculation considering the liquid breakage phenomenon remains as a future work.

4.4. Application to Ironmaking Process

In the lower part of the BF, two phases of liquid iron and molten slag coexist. Even though they are formed from the same materials such as iron ore and coal, they have

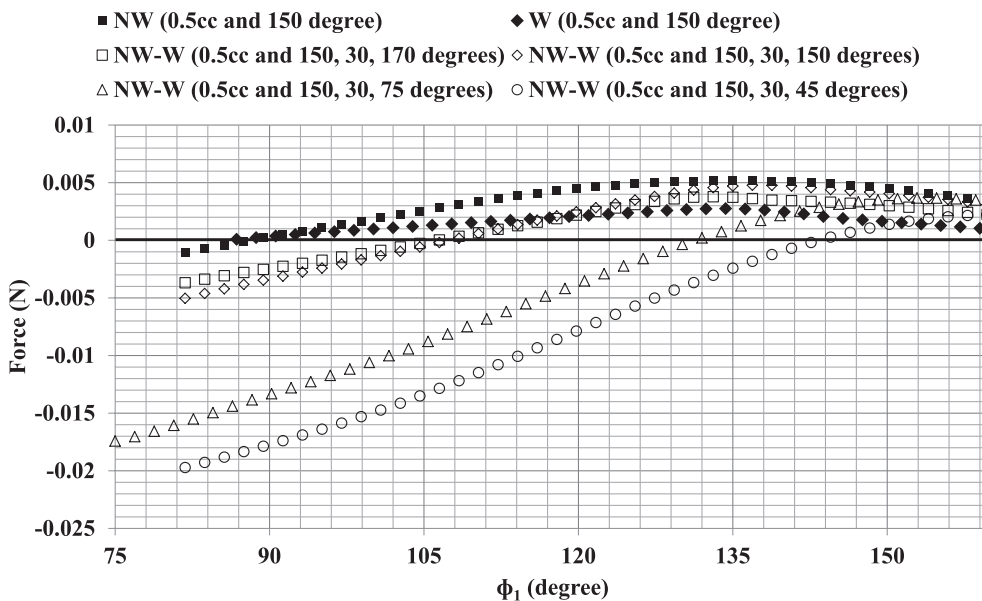

Fig. 10. Force balance plot of 0.5 cc metal and 0.5 cc slag drops in the packed bed.

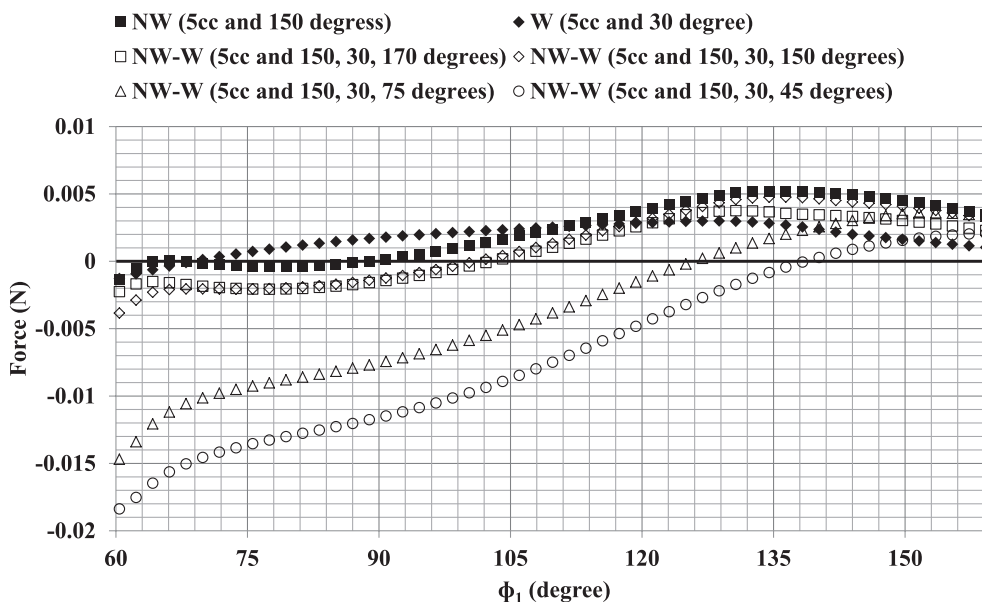

Fig. 11. Force balance plot of 5.0 cc metal and 5.0 cc slag drops in the packed bed.

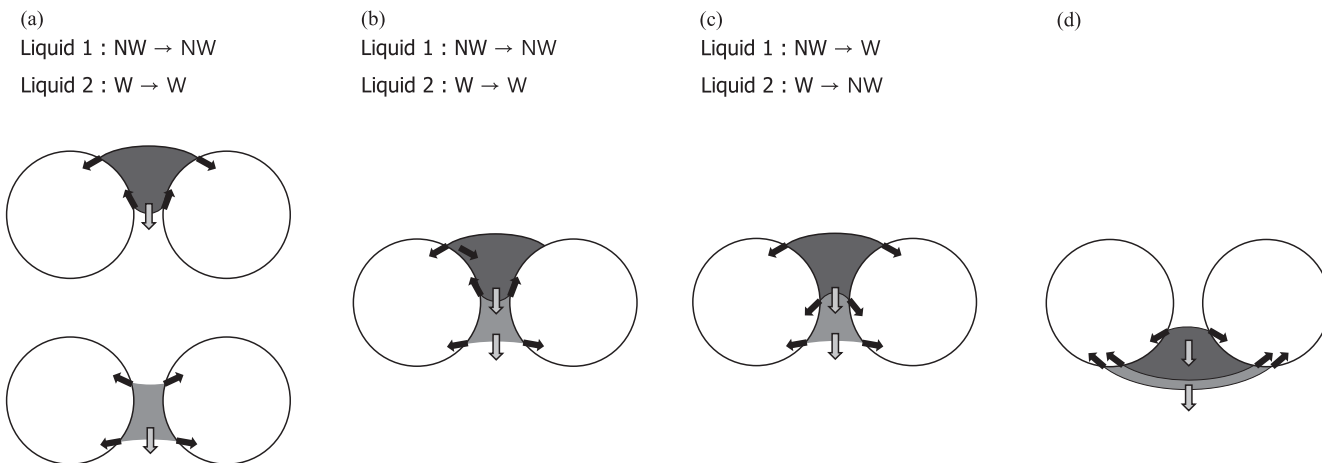

Fig. 12. Illustration of force balance change induced by contact angle change.

drastically different physical properties and phases. For the smooth iron making process using coke bed, the fluent behavior of liquid materials are significantly required. Since molten slag has less density and higher viscosity than liquid iron, it has been considered to cause liquid hold-up problem in ironmaking process using coke bed. Kawabata *et al.*³⁾ showed that the hold-up problem was mainly related to the interfacial tension of liquid materials. In this sense, it is necessary to figure out the mechanism and to develop the method of establishing the fluent liquid flow.

Based on the previous research by Jeong *et al.*,¹⁵⁾ it was attempted to analytically calculate the multiphase flow mechanism in order to overcome the interfacial force effect of liquid drops in a packed bed of small particles. In addition, the force balance based on three dimensional geometry was successfully illustrated. According to the results obtained in the current study, the direct contact of liquid iron and molten slag can play the positive role each other in the smooth trickle down of both liquid materials by reducing their interfacial force effect. In short, liquid iron and molten slag are required to flow through the same channels in a coke bed for the direct contact between them even after they are reduced and separated into the materials of different phases. The method of inducing such flow behavior is not suggested in this study because it needs further idea and research.

5. Conclusions

From the calculation results, the following conclusions were obtained:

(1) In a packed bed system, the interfacial tensions of liquid drops highly affect their flow behavior by changing the direction of the interfacial tensions in the liquid-solid-gas interface.

(2) Regardless of the wettability of a liquid drop, the

interfacial tension induces the resisting force against the gravitational force. In short, the interfacial tension interrupts the flow of a liquid drop along the direction of the gravitational force.

(3) When two liquid drops of different phases directly contact each other in a packed bed, one of the interfaces of each drop is shared and the influence of the interfacial force decreased so that the liquid drops can move down mostly through the void between particles than a single drop.

(4) If the shared interface of two liquid drop has lower contact angle than that of the liquid-gas interface of the NW liquid drop, then the drops experience the downward force along the gravitational direction in the larger range of the position in the packed bed.

REFERENCES

- 1) J. Yagi: *ISIJ Int.*, **33** (1993), 619.
- 2) H. Jin, S. Choi, J.-I. Yagi and J. Chung: *ISIJ Int.*, **50** (2010), 1023.
- 3) H. Kawabata, Z. Liu, F. Fujita and T. Usui: *ISIJ Int.*, **45** (2005), 1466.
- 4) H. Kawabata, K. Shinmyou, T. Harada and T. Usui: *ISIJ Int.*, **45** (2005), 1474.
- 5) K. Saito, K. Ohno, T. Miki, Y. Sasaki and M. Hino: *ISIJ Int.*, **46** (2006), 1783.
- 6) W. M. Husslage, M. A. Reuter, R. H. Heerema, T. Bakker and A. G. S. Steeghs: *Metall. Mater. Trans. B*, **36B** (2005), 765.
- 7) G. S. Gupta, J. D. Litster, E. T. White and V. R. Rudolph: *Metall. Mater. Trans. B*, **28B** (1997), 597.
- 8) G. X. Wang, S. J. Chew, A. B. Yu and P. Zulli: *Metall. Mater. Trans. B*, **28B** (1997), 333.
- 9) Y. Bando, S. Hayashi, A. Matsubara and M. Nakamura: *ISIJ Int.*, **45** (2005), 1461.
- 10) D. Megias-Alguacil and L. J. Gauckler: *AIChE J.*, **55** (2009), 1103.
- 11) T. W. Kang, S. Gupta, N. Saha-Chaudhury and V. Sahajwalla: *ISIJ Int.*, **45** (2005), 1526.
- 12) K. Nishioka, D. Fujiwara, K. Ohno, T. Maeda and M. Shimizu: *ISIJ Int.*, **50** (2010), 1016.
- 13) G. S. Gupta and K. Naveen: *Metall. Mater. Trans. B*, **38B** (2007), 203.
- 14) L. Baussaron, C. Julcour-Lebigue, A.-M. Wilhelm and H. Delmas: *AIChE J.*, **53** (2007), 1850.
- 15) I.-H. Jeong, H.-S. Kim and Y. Sasaki: *ISIJ Int.*, **53** (2013), 2090.
- 16) G. K. Batchelor: *An Introduction to Fluid Dynamics*, Cambridge University Press, Cambridge, (2000), 60.